

# Installation Instructions

**NOTE:** Read the entire instruction manual before starting the installation.

## TABLE OF CONTENTS

	PAGE
SAFETY CONSIDERATIONS .....	1
INTRODUCTION .....	2
INSTALLATION .....	2
Inspect Equipment .....	2
Select Installation Procedure .....	2
Installation of Evaporator Coils .....	2
Connect Refrigerant Piping .....	4
Connect Lines .....	5
Refrigerant Metering Device .....	5
Condensate Drain Line Connection .....	5
Waste Line Connection .....	6
CARE AND MAINTENANCE .....	6
CARE AND MAINTENANCE .....	7

## SAFETY CONSIDERATIONS

Improper installation, adjustment, alteration, service, maintenance, or use can cause explosion, fire, electrical shock, or other conditions which may cause death, personal injury or property damage. Consult a qualified installer, service agency, or your distributor or branch for information or assistance. The qualified installer or agency must use factory-authorized kits or accessories when modifying this product. Refer to the individual instructions packaged with the kits or accessories when installing.

Follow all safety codes. Wear safety glasses, protective clothing, and work gloves. Use quenching cloth for brazing operations. Have fire extinguisher available. Read these instructions thoroughly and follow all warning or cautions included in literature and attached to the unit. Consult local building codes and the current editions of the National Electrical Code (NEC) NFPA 70.

In Canada, refer to the current editions of the Canadian Electrical Code CSA C22.1.

Recognize safety information. When you see this symbol  on the unit and in instructions or manuals, be alert to the potential for personal injury. Understand the signal words **DANGER**, **WARNING**, **CAUTION**, and **NOTE**. These words are used with the safety-alert symbol. **DANGER** identifies the most serious hazards which **will** result in severe personal injury or death. **WARNING** signifies hazards which **could** result in personal injury or death. **CAUTION** is used to identify unsafe practices which **may** result in minor personal injury or product and property damage. **NOTE** is used to highlight suggestions which **will** result in enhanced installation, reliability, or operation.

## WARNING

### ELECTRICAL SHOCK HAZARD

Failure to follow this warning could result in personal injury or death.

Before installing, modifying or servicing system, always turn off main power to system. There may be more than one disconnect switch. Lock out and tag switch with a suitable warning label.

## CAUTION

### UNIT OR PROPERTY DAMAGE HAZARD

Failure to follow this caution may result in property damage.

Take precautions to ensure Aluminum tubes do not come in direct contact or allow for condensate run off with a dissimilar metal. Dissimilar metals can cause galvanic corrosion and possible premature failure.

## WARNING

### EXPLOSION HAZARD

Failure to follow this warning could result in death, serious personal injury, and/or property damage.



Never use air or gases containing oxygen for leak testing or operating refrigerant compressors. Pressurized mixtures of air or gases containing oxygen can lead to an explosion.

## CAUTION

### CUT HAZARD

Failure to follow this caution may result in personal injury.

Sheet metal parts may have sharp edges or burrs. Use care and wear appropriate protective clothing and gloves when handling parts.



# CAUTION

## PERSONAL INJURY HAZARD

Failure to follow this caution may result in personal injury.

This coil contains Nitrogen precharge of 15 PSIG. Release of this pressure through the center of the rubber plugs is required before removing the plugs.

**IMPORTANT:** Nitrogen can leak out through the hole that the needle pierced in the plugs. This does not indicate a leaking coil nor warrant return of the coil.



# CAUTION

## ENVIRONMENTAL HAZARD

Failure to follow this caution may result in environmental damage.

Federal regulations require that you do not vent refrigerant to the atmosphere. Recover during system repair or final unit disposal.

## INTRODUCTION

Use this instruction manual to install CAPMP indoor coil on multipoise furnaces. (See Fig. 1.) The CAPMP coil is enclosed in a casing.

Table 1		COIL INFORMATION		
MODEL	SIZE (TON)	FLUSH FIT TO FURNACE WIDTH	COIL CONNECTION TUBE SIZE (IN.)	
			Liquid	Suction
CAPMP1814ALA	1.5	14-3/16" / 360 mm	3/8	5/8
CAPMP1917ALA	1.5	17-1/2" / 445 mm	3/8	3/4
CAPMP2414ALA	2.0	14-3/16" / 360 mm	3/8	5/8
CAPMP2417ALA	2.0	17-1/2" / 445 mm	3/8	5/8
CAPMP2517ALA	2.0	17-1/2" / 445 mm	3/8	3/4
CAPMP3014ALA	2.5	14-3/16" / 360 mm	3/8	3/4
CAPMP3017ALA	2.5	17-1/2" / 445 mm	3/8	3/4
CAPMP3614ALA	3.0	14-3/16" / 360 mm	3/8	3/4
CAPMP3617ALA	3.0	17-1/2" / 445 mm	3/8	3/4
CAPMP3717ALA	3.0	17-1/2" / 445 mm	3/8	3/4
CAPMP3721ALA	3.0	21" / 533 mm	3/8	7/8
CAPMP4221ALA	3.5	21" / 533 mm	3/8	7/8
CAPMP4321ALA	3.5	21" / 533 mm	3/8	7/8
CAPMP4821ALA	4.0	21" / 533 mm	3/8	7/8
CAPMP6021ALA	5.0	21" / 533 mm	3/8	7/8
CAPMP6121ALA	5.0	21" / 533 mm	3/8	7/8
CAPMP6024ALA	5.0	24-1/2" / 622 mm	3/8	7/8
CAPMP6124ALA	5.0	24-1/2" / 622 mm	3/8	7/8

## INSTALLATION

### INSPECT EQUIPMENT

File claim with shipper if equipment is damaged.

### SELECT INSTALLATION

For upflow application follow:

See **Table 1** for dimensions. Note instructions for placement of coil casing on furnace.

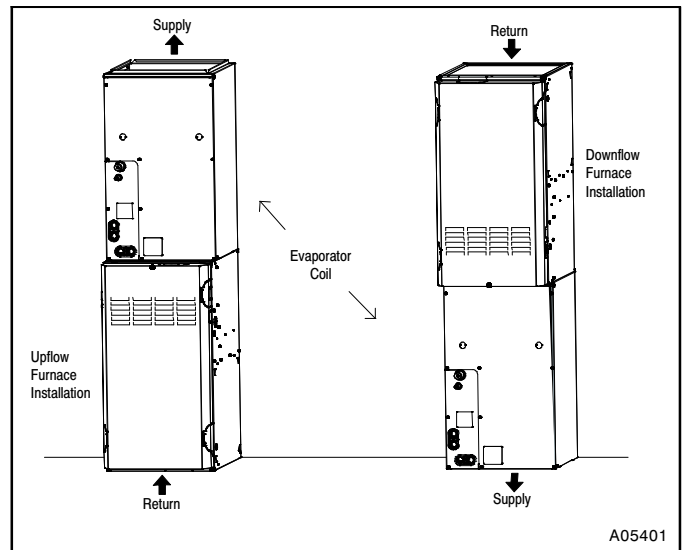
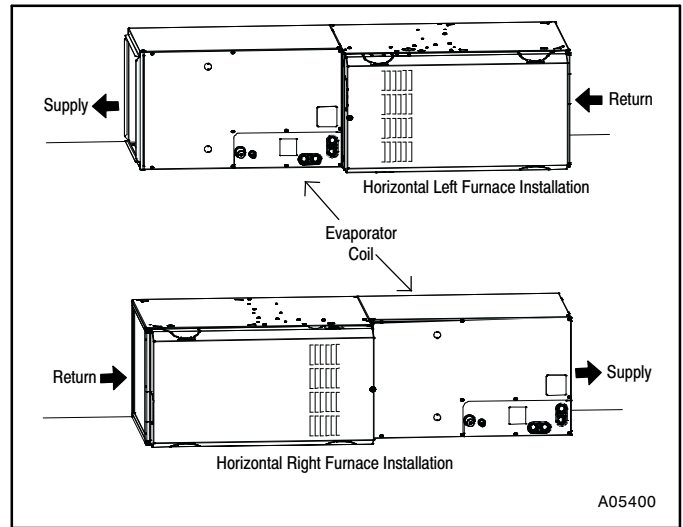

Figure 1 – Typical Coil Installation on Furnace

## INSTALLATION OF EVAPORATOR COILS

### Upflow coil installation

The cased coil is designed to fit furnaces of the same width.

1. Set coil in place on upflow furnace discharge air opening.
2. Ensure coil is level for proper condensate drainage. Do not tip coil toward condensate drain. Coil casing need not be fastened or screwed to furnace.
3. When installing wider coil on narrow furnace, create field fabricated adapter. (See **Figure 2**)

**NOTE:** On upflow installations where the indoor coil is placed in an unconditioned space, a 6" wide piece of insulation should be applied and wrapped around the outside of coil casing and supply duct contact point.

**NOTE:** Consult the furnace installation instructions for any special requirements when installing the coil to the furnace.

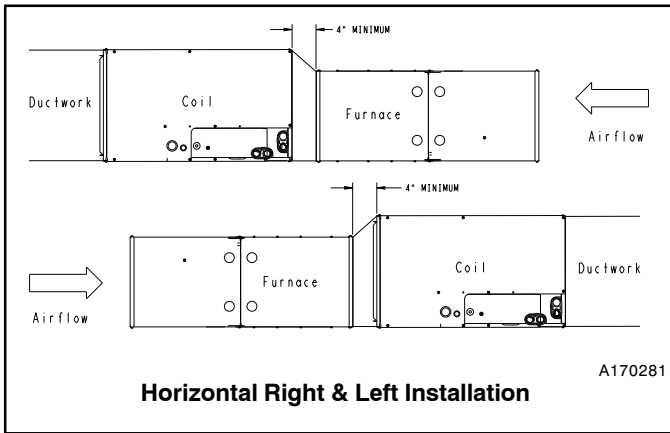

**Horizontal Right & Left Installation**

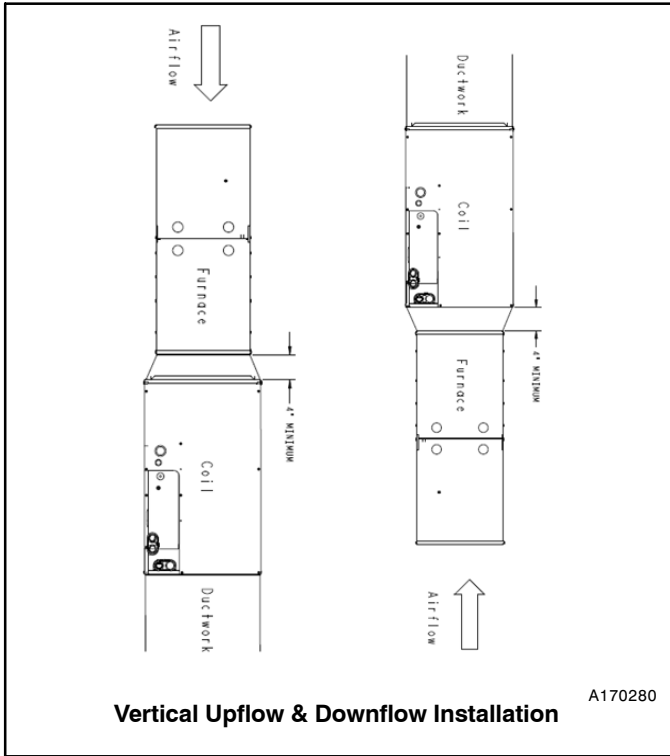

**Vertical Upflow & Downflow Installation**

**Figure 2 – Adapter(s) Installation When Coil Overhangs Furnace**

**Downflow Coil Installation**

**IMPORTANT:** Installing “A” coils rotated 90 degrees from the front of the furnace in downflow applications can cause water blow off or coil freeze up. This is due to the concentration of air on one coil slab or lack of air on the opposite coil slab. If the airflow is high due to ductwork or other causes, and there is a chance for water blow off, it is recommended that a 4-in. minimum field-supplied adapter be placed between the coil and the furnace to allow the air to distribute evenly to both coil slabs. (See **Figure 3**)

4. Set cased coil on supply duct opening.
5. Place field fabricated 4-in. minimum adapter on coil casing. Adapter should be tapered to fit coil/furnace combination when one of them is larger than the other.
6. Set furnace on adapter.

**NOTE:** In downflow installation with a 4-way multipoise furnace, break off perforated duct flanges on furnace. See furnace installation instructions.

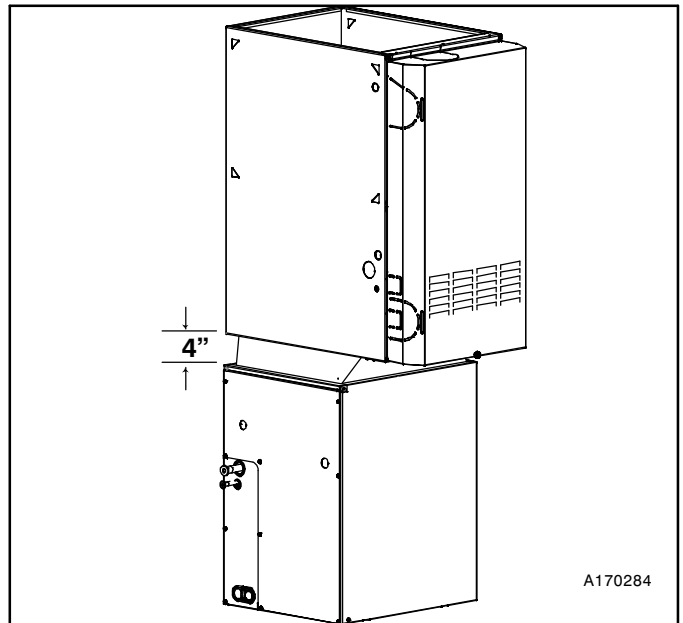

**Figure 3 – Downflow Installation with Coil Rotated 90°**

**Horizontal Coil Installation**

The unit can be installed on a work platform, secured to roof truss in attic, suspended from hangers on floor joists in crawl space, or installed on blocks. It is designed to allow airflow in either direction, to mate with horizontal-left or horizontal-right furnace installations. Ensure coil cabinet is level side to side and front to back. It is allowable to add up to 1/2-in. additional slope over length and depth of coil cabinet in the direction of drain pan connection.

**Horizontal Right Installation**

1. Use field fabricated attachment plates to secure coil to furnace. (See **Figure 4**)
2. Use self-tapping screws to mount attachment plates to coil casing.

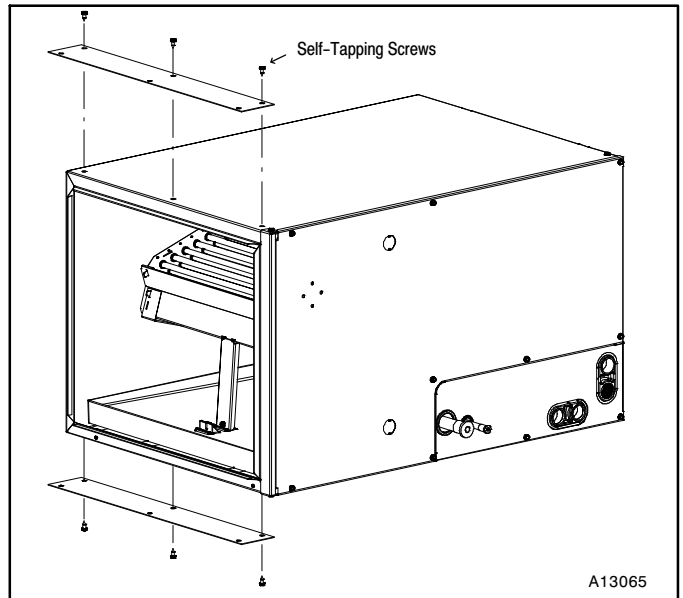

**Figure 4 – Horizontal Right Installation**

3. Connect furnace snugly against coil casing.
4. Use self-tapping screws to attach furnace. (See **Figure 5**)
5. Seal joint between coil casing and furnace to create an air tight seal using locally approved materials.

6. Use cork tape to create air seal between the undersides of the pan extension and front of the vertical drain pan as shown in **Figure 6**.
7. Install included condensate pan extension and two corner screws as shown in **Figure 7**.
8. If coil is wider than furnace, use 4-in minimum transition and self tapping screws to attach furnace. (See **Figure 2**)

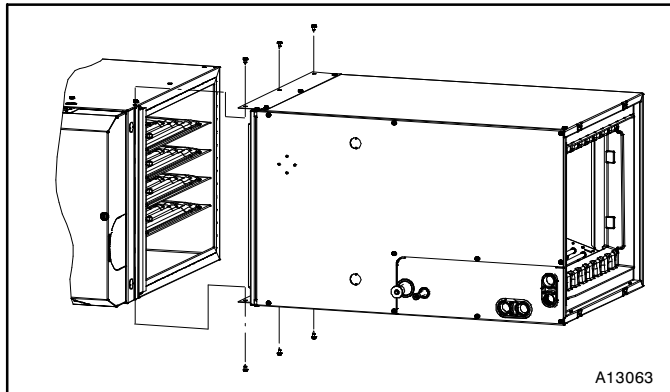

**Figure 5 – Horizontal Right Installation**

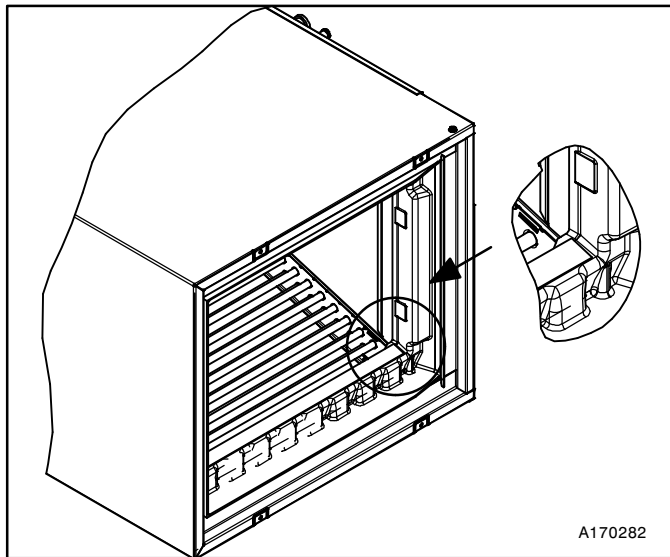

**Figure 6 – Condensate Pan Extension Cork Tape Location**

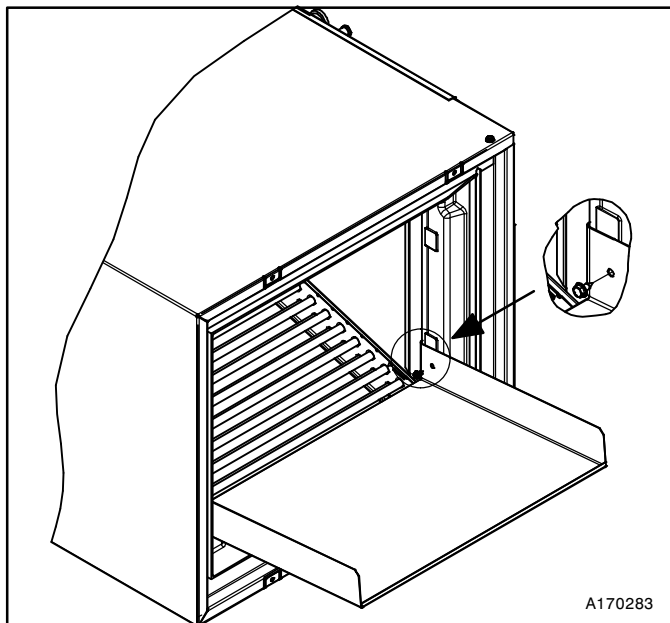

**Figure 7 – Condensate Pan Extension Mounting Screws**

#### Horizontal Left Installation

1. Unbend the 4 tabs at the right side of the casing. (See **Figure 8**)
2. Connect furnace snugly against coil casing.
3. Use self-tapping screws to attach furnace. (See **Figure 9**)
4. Seal joint between coil casing and furnace to create air tight seal using locally approved materials.
5. If coil is wider than furnace, use 4-in. Minimum transition and self tapping screws to attach furnace. (See **Figure 2**)

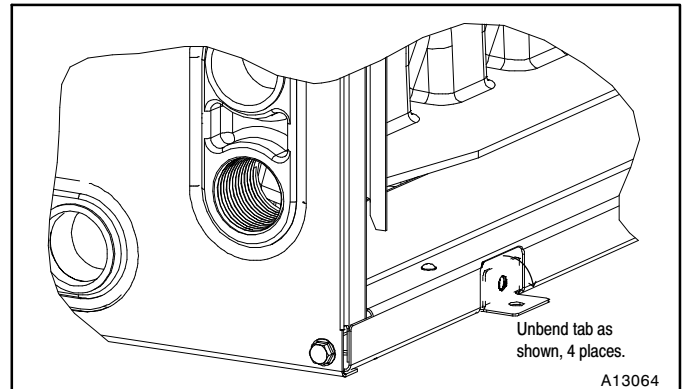

**Figure 8 – Horizontal Left Installation**

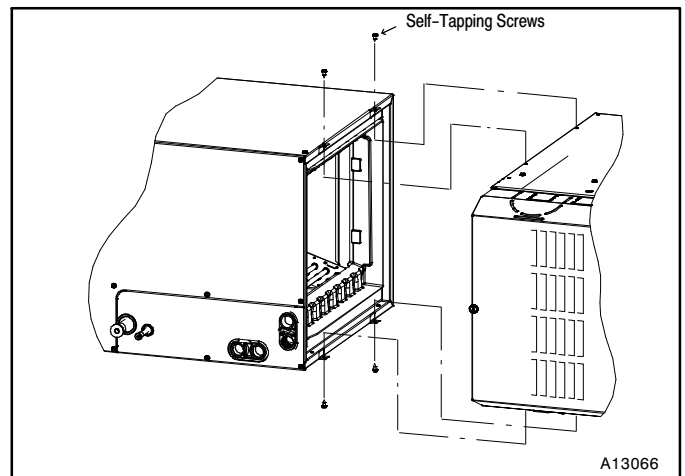

**Figure 9 – Horizontal Left Installation**

#### REFRIGERANT LINE CONNECTIONS



## WARNING

#### PERSONAL INJURY HAZARD

Failure to follow this warning could result in personal injury. Wear eye protection.

Coil is factory charged with 15 psi nitrogen. The coil is under pressure and TXV screen is in place behind liquid line plug. DO NOT remove liquid line plug first, always remove the suction line plug first to depressurize the coil.

**NOTE:** Factory nitrogen charge may escape past rubber plugs during storage. This does not indicate a leaking coil nor warrant return of the coil.

Size and install refrigerant lines according to information provided with outdoor unit. Coil connection tube sizes are shown in **Table 1**. Route refrigerant lines to the coil in a manner that will not obstruct service access to the unit or removal of the filter.

Do not use damaged, dirty, or contaminated tubing because it may plug refrigerant flow-control device. ALWAYS evacuate the coil and field-supplied tubing before opening outdoor unit service valves.

### CONNECT REFRIGERANT, LIQUID, and SUCTION LINES

For matched and mismatched systems, use line sizes recommended in outdoor unit Installation Instructions.

 **CAUTION**

**UNIT OR PROPERTY DAMAGE HAZARD**

Failure to follow this caution may result in property damage. Take precautions to ensure Aluminum tubes do not come in direct contact or allow for condensate run off with a dissimilar metal. Dissimilar metals can cause galvanic corrosion and possible premature failure.

The coil can be connected to outdoor units using field-supplied tubing of refrigerant grade. Always evacuate tubing and reclaim refrigerant when making connections or flaring tubing. Leak check connections before insulating entire suction line.

See **Table 1** for coil connection tube size.

1. Remove cabinet access door.
2. Remove rubber plugs, suction plug then liquid plug, from coil stubs using a pulling and twisting motion. Hold coil stubs steady to avoid bending or distorting.
3. Remove tubing plate with rubber grommets and slide plate with grommets onto the refrigerant lines (field line-set), away from braze joints.
4. Fit refrigerant lines into coil stubs. Wrap a heat sinking material such as a wet cloth behind braze joints.
5. Wrap TXV and nearby tubing with a heat-sinking material such as a wet cloth.
6. Use 1/2 psig Nitrogen purge in the suction and out the the liquid line.
7. Braze using a Sil-Fos or Phos-copper alloy. Do not use soft solder.
8. After brazing, allow joints to cool. Carefully remove TXV bulb insulation and verify that the TXV bulb is securely fastened with hose clamp. Tighten screw a half-turn past hand tight with TXV bulb placed in the indentation with full contact with the vapor line tube. Re-wrap TXV bulb with insulation.
9. Leak check connections before insulating entire suction line.
10. Slide tubing plate with rubber grommets over joints. Position tubing at center of each grommet to ensure an air seal around the tube. Reinstall cabinet door.

 **CAUTION**

**UNIT DAMAGE HAZARD**

Failure to follow this caution may result in product damage. To avoid valve damage to the refrigerant control device while brazing, valves must be wrapped with a heat-sinking material such as a wet cloth.

### REFRIGERANT METERING DEVICE

These Coils have a factory installed hard shut-off TXV designed only for use with R-410A refrigerant. Use only with outdoor units designed for R-410A.

**NOTE: ALL TXV'S HAVE PRESET SUPERHEAT SETTINGS AND ARE FIELD NON-ADJUSTABLE.**

 **CAUTION**

**UNIT DAMAGE HAZARD**

Failure to follow this caution may result in product damage.

**DO NOT BURY MORE THAN 36 IN. OF REFRIGERANT TUBING IN GROUND.** If any section of tubing is buried, there must be a 6 in. vertical rise to the valve connections on the outdoor unit. If more than the recommended length is buried, refrigerant may migrate to cooler buried section during extended periods of unit shutdown, causing refrigerant slugging and possible compressor damage at start-up.

### CONDENSATE DRAIN LINE CONNECTION

 **CAUTION**

**PROPERTY DAMAGE HAZARD**

Failure to follow this caution may result in property damage.

When installing over a finished ceiling and/or living area, install a field-fabricated secondary condensate pan under the entire unit.

The coil is designed to dispose of accumulated water through built-in condensate drain fittings. It is recommended that PVC fittings be used on the condensate pan. Do not over-tighten. Finger tighten plus 1-1/2 turns. Be sure to install plastic plug in unused condensate drain fitting. Two 3/4 inch female threaded pipe connections are provided in each coil condensate pan.

A trap is not necessary on the condensate line if on the supply air side of furnace. Consult local codes for additional restrictions or precautions. If local codes require a trap then the following guidelines are suggested to assure proper drainage. Install a trap in condensate line of coil as close to the coil as possible. Make trap at least 3 inches (76 mm) deep and no higher than the bottom of unit condensate drain opening (See **Figure 10**). Pitch condensate line 1 inch (25.4 mm) for every 10 ft. of length to an open drain or sump. Make sure that the outlet of each trap is below its connection to condensate pan to prevent condensate from overflowing the drain pan. Prime all traps, test for leaks, and insulate traps and lines if located above a living area.

 **WARNING**

**EXPLOSION HAZARD**

Failure to follow this warning could result in personal injury or death.

Provide trap with air gap in drain line when connecting to waste (sewer) line.

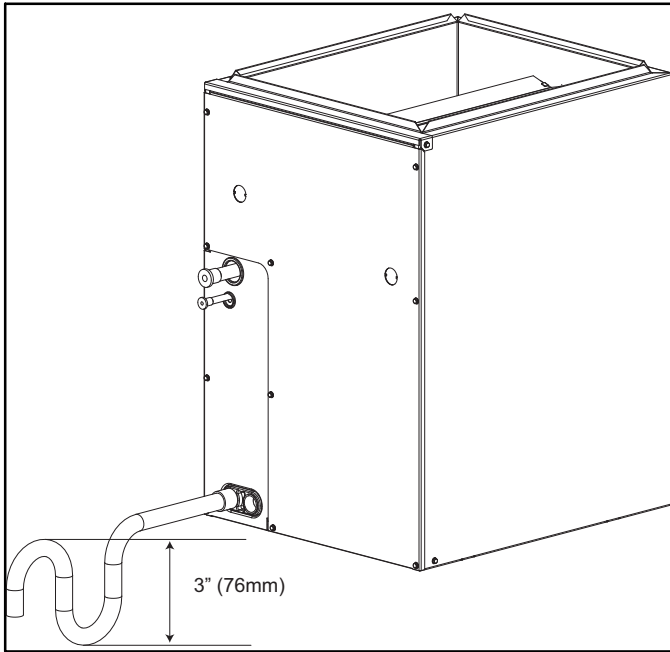

**Figure 10 – Condensate Trap**

A13067

**NOTE:** If unit is located in or above a living space, where damage may result from condensate overflow, a field-supplied, external condensate pan should be installed underneath the entire unit, and a secondary condensate line (with appropriate trap) should be run from the unit into the pan. Any condensate in this external condensate pan should be drained to a noticeable place. As an alternative to using an external condensate pan, some localities may allow the running of a separate 3/4 inch (19 mm) condensate line (with appropriate trap) per local code to a place where the condensate will be noticeable. The owner of the structure must be informed that when condensate flows from secondary drain or external condensate pan, the unit requires servicing or water damage will occur. To further protect against water damage, install a float switch to shut the unit off if the water in the secondary pan gets too high.

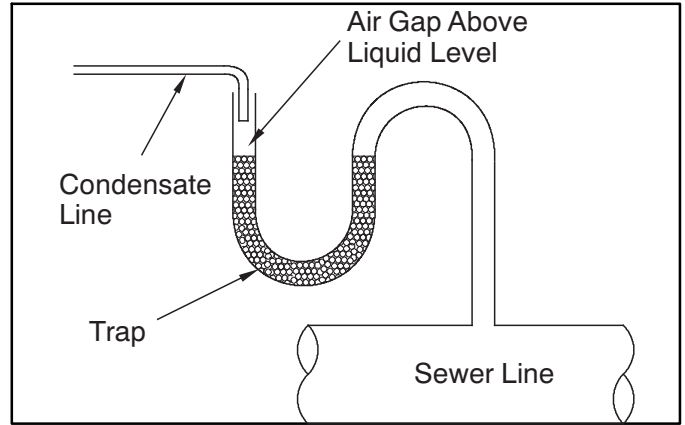

**Figure 11 – Condensate Drain to Waste Line**

A10216

### WASTE LINE CONNECTION

If the condensate line is to be connected to a waste (sewer) line, an open trap must be installed ahead of the waste line to prevent escape of sewer gases (See **Figure 11**)

### CARE AND MAINTENANCE

To continue high performance and minimize possible equipment failure, it is essential that periodic maintenance be performed on this equipment. Consult your local dealer as to the proper frequency of maintenance, but it should be done at least annually.

The ability to properly perform maintenance on this equipment requires certain mechanical skills and tools. If you do not possess these, contact your dealer for maintenance. The only consumer service recommended or required is filter replacement or cleaning on a monthly basis.

**⚠ CAUTION**

**ENVIRONMENTAL HAZARD**

Failure to follow this caution may result in environmental damage.

Remove and recycle all components or materials (i.e., oil, refrigerant, etc.) before unit final disposal.